

**HARYANA FOREST DEVELOPMENT CORPORATION LTD.  
(A Government of Haryana Undertaking)**

1



**TENDER DOCUMENT**

**TENDER NO. : GM/HFDC/RWR/03/2019-20**

**Name of Work: Manufacturing of Steel Almirah with Material at  
Furniture Workshop at Masani Barrage, District  
Rewari.**

**Haryana Forest Development Corporation Ltd.  
(A Government of Haryana Undertaking)**

**General Manager, Rewari**  
Off Address: Masani Barrage, NH-8  
Near Village Khaliawas, P.O. Dharuhera  
District Rewari-123106, Haryana  
E-mail: gm.rewari@hfdc.gov.in

---

**Telephone : 0124-2305348; 8178231026**  
**E-mail: [gm.rewari@hfdc.gov.in](mailto:gm.rewari@hfdc.gov.in) Website: [www.hfdc.gov.in](http://www.hfdc.gov.in)**

---

## Index

<b>S. No.</b>	<b>Description</b>	<b>Page No.</b>
1.	Notice Inviting Tender	3
2.	Detailed Notice Inviting Tender	4
3.	Key Dates	4
4.	Scope of Work	5
5.	Terms & Conditions	6-9
6.	Technical Bid	10
7.	Financial Bid	11-15
8.	Undertaking	16
9.	Affidavit	17
10	Standard Agreement Form	18

# **Haryana Forest Development Corporation Limited**

(A Government of Haryana Undertaking)

**General Manager, Rewari**

Off Address: Masani Barrage, NH-8  
Near Village Khaliawas, P.O. Dharuhera  
District Rewari-123106, Haryana



E-mail: gm.rewari@hfdc.gov.in

**No. GM/HFDC/RWR/03/2019-20**

**Dated: 24.06.2019**

## **TENDER NOTICE**

Sealed tenders are invited under Two Bid System from the eligible bidders/agencies/firms through website [www.hfdc.gov.in](http://www.hfdc.gov.in) in for **Manufacturing of Steel Almirah with Material at Furniture Workshop at Masani Barrage, District Rewari as per specifications and drawing.**

The tender document charges of **Rs. 590/-** (Rs. 500/- cost of tender document + 90/- G.S.T.) and **E.M.D of Rs. 40000/- (Rs. Forty thousand only)** are to be paid in the form of Demand Draft in favour of Haryana Forest Development Corporation Ltd. The tender documents will be available on the HFDC website [www.hfdc.gov.in](http://www.hfdc.gov.in) from 24.06.2019. Last date for submission of Tender is 04.07.2019 (till 02:00 P.M.) The technical bids will be opened on 04.07.2019 (03:00 P.M. onwards) and financial bids will be opened on 04.07.2019 (04:00 P.M. onwards). If the tenders are cancelled or recalled on any grounds, the tender document fee will not be refunded. EMD will be returned back in such circumstances.

**General Manager  
H.F.D.C. Rewari**

## DETAIL NOTICE INVITING TENDER

**Sealed Tenders** are invited for below mentioned works in single stage two cover system i.e. Pre-Qualification/ Technical Bid (Technical Envelope) and Request for Financial Bid (comprising of price bid proposal):-

Sr. No	Description of Works	EMD to be deposited by Bidder	Tender Document Fee (Rs.)	Date of tender document can be downloaded at HFDC website (www.hfdc.gov.in)	Expiry Date & Time of Bid of EMD Submission	Expiry Date & Time of Bid Preparation & Submission
1.	As per Scope of Works (Attached)	Rs. 40000/-	590/-	24.06.2019 09.00 AM	04.07.2019 02:00 P.M.	04.07.2019 02:00 P.M.

The Bidders can submit their tender documents as per the dates mentioned in the key dates:

### Key Dates

Sr. No.	Department Stage	Bidder's Stage	Start Date and Time	Expiry Date and Time
1		<b>Tender Document Download and Bid Preparation/Submission</b>	24.06.2019 09.00AM	04.07.2019 02:00 P.M.
2	<b>Technical Bid Opening</b>		04.07.2019 (03:00 PM)	
3	<b>Financial Bid Opening</b>		04.07.2019 (04:00 PM)	

#### **Important Note:**

- 1) The Applicants/bidders have to complete 'Application/Bid Preparation & Submission' stage on scheduled time as mentioned above. If any Applicant/bidder failed to complete his/her aforesaid stage in the stipulated online time schedule for this stage, his/her Application/bid status will be considered as 'Applications/bids not submitted'.
- 2) Applicant/Bidder must confirm & check his/her Application/bid status after completion of his/her all activities for bidding.
- 3) Applicant/Bidder can rework on his/her bids even after completion of 'Application/Bid Preparation & submission stage' (Application/Bidder Stage), subject to the condition that the rework must take place during the stipulated time frame of the Applicant/Bidder Stage.
- 4) In the first instance, the payment details of tender document fee and EMD & PQQ/Technical Envelope shall be opened. Henceforth financial bid quoted against each of the item by the shortlisted bidder/Agency wherever required shall be opened in the presence of such bidders/Agency who either themselves or through their representatives choose to be present. The bidder can submit their bids as per the dates mentioned in the schedule/Key Dates above.

The bids shall be submitted in two separate envelopes:

#### **Envelope 1: Technical Bid**

The bidders shall prepare the required eligibility & technical documents in the Technical Bid alongwith cost of tender document and EMD.

#### **Envelope 2: Financial Bid**

The bidders shall submit mandatorily financial bid under prescribed format.

## Scope of works

The tentative details of description of work, amount and time schedule for completing the work is given as under:-

Description of Work	Approximate Cost in Rs.	Contract period
<b>Manufacturing of Steel Almirah with Material at Furniture Workshop at Masani Barrage, District Rewari as per specifications and drawing</b>	20.00 lakhs	3 months

**N.B.:-**

- 1. Works can be increased or decreased depending upon the availability of work-order.**

Bidding Documents can be downloaded from the HFDC website [www.hfdc.gov.in](http://www.hfdc.gov.in) by the contractor/agency registered on HFDC by paying document fee. The tender document may also be obtained from office of GM, HFDC, Rewari/Gurgaon on payment of document fee on any working day.

**General Manager  
H.F.D.C. Rewari**

## **TERMS & CONDITIONS OF THE TENDER**

1. Sealed Tenders are invited for **Manufacturing of Steel Almirah with Material at Furniture Workshop at Masani Barrage, District Rewari as per specifications and drawing.**
2. The successful tenderer/bidder shall be required to execute the work as specified in the Tender Application Form within 10 days time from the date of communication of the approval of the Competent Authority.
3. Estimated cost of work: Rs. 20.00 lakhs.
4. Participation in the bid shall amount to bidder's acceptance of the terms and conditions of the tender.
5. **The bidder shall submit on or before the closing date given in the Notice Inviting Tender, the Technical Bid and the Financial Bid in the prescribed format.**
6. The **Technical Bid** should consist of the following documents:
  - a. Bid Security (Earnest Money Deposit) for an amount of **Rs. 40000/-** in the form of Demand Draft from any bank **drawn** in favour of Haryana Forest Development Corporation Ltd. payable at Rewari unless or otherwise exempted. The EMD in original shall be submitted in the office of GM, HFDC, Rewari on or before **the closing date and time i.e. 04.07.2019 up to 02.00 pm** as part of the Technical bid.
  - b. Tender document fee of Rs. 590/-
  - c. Self attested copy of civil works executed in past
  - d. Self attested copy of Registration with HFDC/Haryana Forest Department/other govt. agency.
  - e. Self attested copy of PAN Card
  - f. Self attested copy of GSTIN certificate
  - g. Self attested of Registration with EPF,ESI and Labour Department

**Tenderer/Bidder must submit copies of all documents required alongwith tender document.**

7. **Financial Bid** : The Tenderer/Bidder shall quote the rates in the prescribed form for Price Bid given in this tender on a 'single responsibility' basis such that the Tender price covers contractor's all obligations and liabilities. The rates and prices quoted by the Bidder shall be inclusive of all Taxes. The rate quoted shall be responsive and the same should be inclusive of all Statutory obligations such as Minimum Wages, ESI, PF contributions, wages for leave reserve, service charges, all kind of taxes etc. The offers of those prospective bidders which do not meet the statutory requirements are liable to be rejected. Conditional bids/offers will be summarily rejected
8. The tenderer/Bidder is expected to examine all instructions, Forms, Terms and Conditions in the Tender document before participation in this tender.
9. In case the tenderer/Bidder has any doubt about the meaning of anything contained in the tender document, he shall seek clarification from the office of the General Manager, Haryana Forest Development Corporation Ltd., Nature Camp on NH-8, Masani Barrage, Near Village Khaliawas, District Rewari (Haryana), Tel. No. 0124-2305348, E-mail- gm.rewari@hfdc.gov.in.
10. The bidder may visit the site before bidding if they desire to visit with prior information to above address.
11. Bid securities (EMD) of the unsuccessful tenderer/bidder will be returned to them at the earliest. Bid security of the successful bidder shall be returned on deposition of Performance Security/Security Deposit of 5% of the bid value of the bid value. Bid Security shall be forfeited if the Tenderer/Bidder withdraws his bid during the period of tender validity. Bid Security shall also be liable to be forfeited if the successful bidder fails to furnish the required Performance Security within the time frame specified by HFDC.
12. The successful tenderer/bidder shall execute an agreement with General Manager, Haryana Forest Development Corporation Ltd., Rewari (Haryana) soon after deposit of 5% of the tendered value as Performance Guarantee within 10 days w.e.f. the date of acceptance of the offer in the form of Demand Draft/Fixed Deposit Receipt/Bank Guarantee having a validity of 180 days w.e.f. the date of acceptance of the offer, drawn from any of the Commercial Bank payable at Rewari in favour of General Manager, Haryana Forest Development Corporation Ltd., Rewari (Haryana).
13. The Technical Bids will be opened in the presence of the Tenderer/Bidders or their representatives who choose to attend at the appointed place and time. The Qualification for the technical bid shall be based on the online receipt of all the documents required & listed above in clause No. 6 on or before the closing date and time of bidding i.e. **04.07.2019 up to 02.00 pm.**
14. Financial Bids/Price Bids of only the technically qualified bidders will be opened for evaluation in the presence of qualified bidders who choose to be present at the time of opening of Financial Bids. Rates shall be compared on the basis of total cost for all the items taken together for approved Technical bid.
15. Preference for works upto Rs. 50.00 lacs shall be given to the registered Labour Co-operative & Construction Societies as per directions of the Haryana Government issued vide No. 8366-C-7-2016/13818 dated 08.12.2016. The EMD for such registered Societies shall be Rs. 25000/- or 1% of the value of work, whichever is less. If the work is awarded to such registered societies being found L-1, 1% on every bill shall be deposited as contribution to the Haryana State Labour Co-operative & Construction Federation Ltd., Panchkula.

16. The offers of tenders not accompanied by documentary proof or do not meet the eligibility criteria as mentioned above shall not be considered. Canvassing or negotiation, direct or indirect, would render the tender liable for exclusion from consideration.
17. The General Manager, HFDC, Rewari or higher authority of HFDC reserves the right to accept or reject any or cancel the tender without assigning any reason thereof.
18. The HFDC is not bound to accept the lowest rate/cost or any bid and may at any time by notice in writing to the bidder(s) terminate the tendering process.
19. The payments may be released on submission of running bills on verification of the works executed by field staff of HFDC and after deducting Income Tax or any other tax or duties as liable as per the prevailing Act/Rules and the instructions/guidelines issued by the Government from time to time.
20. HFDC may terminate the work order if it is found that the contractor is black listed on the previous occasions by any of the Government Departments/Institutions/Local Bodies/Municipalities/Public Sector Undertakings etc. and all the amount paid for subject work will be recovered from the Bidder.
21. The successful Tenderer/Bidder shall ensure full compliance with Tax laws of India with regard to the work order(s) and shall be solely responsible for the same. The successful bidder will comply all the rules & regulations of the land with latest circular/orders issued by various Government Departments applicable to the work and bidder will be solely responsible.
22. Failure of the successful tenderer/bidder to comply with the requirements of above clauses shall constitute sufficient grounds for the annulment of the work order and forfeiture of Bid Security/Performance Security.
23. The successful bidder has to complete the work within the assigned period. Extension may be provided considering the request of the bidders having sufficient genuine reasons for the same and on recommendation of the field staff.
24. The successful bidder has to produce duly completed books of accounts/documents as and when required by HFDC.
25. The rates quoted by the tenderer shall remain valid for the entire period of contract and HFDC shall not be responsible for payment of any extra payment on account of escalation of costs/increase in Minimum Wages etc. during the said period.
26. In the event of non-execution of the work in the prescribed period, the Security Deposit shall be forfeited with the HFDC and the balance work, if any, shall be got executed at the risk and cost of the tenderer by rescinding the contract for the reasons to be recorded by GM, HFDC, Rewari in writing.
27. HFDC shall not be responsible for payment of any compensation on account of any loss caused to the tenderer due to natural calamities or other supervening impossibilities.
28. The success bidder shall not construct any permanent structure at the site of work and shall have no right on the land or asset of the Government. Temporary structures for labour may be allowed with the written permission of GM, HFDC, Rewari.
29. Any complaint of less wage payment/delay in payment of wages may also lead to imposition of penalty including forfeiture of performance guarantee.



30. The work will be carried out in strict supervision of field staff of HFDC and the contractor is also advised to keep his civil expert on site for carrying out of the works in accordance with technical specifications.
31. The tenderer shall abide by the provisions made under the Labour Laws and other relevant Statutes as applicable in execution of the work and shall be responsible for making good/ payment of compensation, if any, to any workman or material during execution of the contract.
32. The Success bidder should ensure adequate cleanliness at the site and will not damage any Govt. infrastructure existing at the site. The damage to government infrastructure on account of carelessness of the tenderer, will be recovered from him/her.
33. In no circumstances, the successful bidder would be allowed to sublet the works in part or whole of the contract, assigned to them.
34. Any dispute or difference arising out of this contract will be resolved through joint discussion of the authorized representatives of the concerned parties. However, if the disputes are not resolved by the joint discussions, then the matter will be referred for Chief General Manager, HFDC, New Delhi whose decision will be binding on both the parties.
35. All disputes arising out of the execution of the agreement shall be subject to the jurisdiction of the Court at Rewari only.

**Date:**

**Place:**

**Signature of the Contractor  
or Authorized Nominee**

**Mobile No. ....**

**E-mail address:.....**

**HFDC**

## Steel Almirah- 78" \* 36" \* 19"

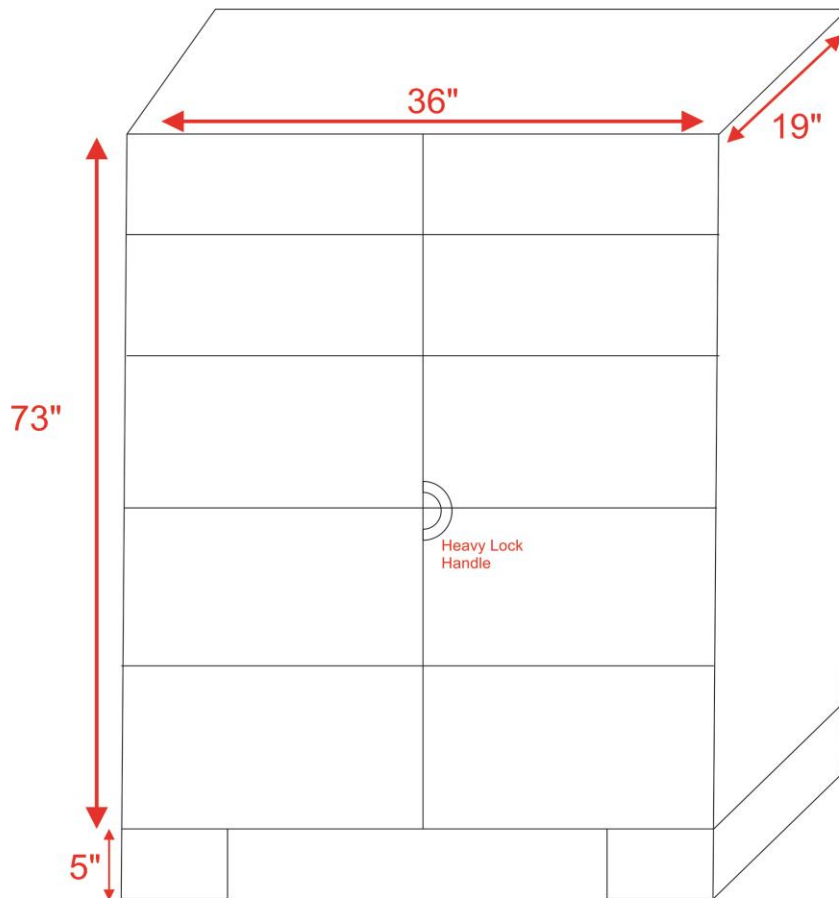

### Specification:-

1. Front Closing Door(Pallo)- 18 Gaug
2. Selves Compartment - 20 Gaug
3. Rest Body - 22 Gaug



H F D C

# Haryana Forest Development Corporation Limited

## General Manager, Rewari

### TENDER APPLICATION FORM (TECHNICAL BID DOCUMENT)

(To be filled by the Tenderer)

#### TENDER APPLICATION FORM- PART-I

Tender for (Name of Work) .....

From:

..... (Name in block letters)

.....

..... ( Address in full).

To

The General Manager

HFDC, Rewari

Sir,

In response to the Tender Notice No. \_\_\_\_\_ Dated \_\_\_\_\_. I..... hereby declare that I have read all the conditions carefully and having agreed to them fully and unconditionally have submitted the financial bid attached with this document. The details mentioned above are true to my knowledge and the documents as listed below are attached herewith.

Documents to be submitted:-

Sr No.	Particulars	Yes	Remarks
1	Signed copy of terms and conditions pages.		
2	Proof of Online payment of Earnest Money Deposit.		
3	GST No.		
4	Copy of PAN Card.		
5	Bank Name		
6	IFSC Code		
7	A/c Number		
8	Work experience with Haryana Forest Department/Haryana Forest Development Corporation (attach attested proof) or any other Government Department/Organization.		
9	Affidavit duly attested by Notary Public (Annexure-I)		
10	Financial Bid in separate cover.		

Signature of contractor

or

Authorized representative of Agency/Firm/Society

Date \_\_\_\_\_

Place \_\_\_\_\_

## Haryana Forest Development Corporation Limited General Manager, Rewari

### TENDER APPLICATION FORM (FINANCIAL BID DOCUMENT) (To be filled by the Tenderer)

#### TENDER APPLICATION FORM- PART-II

Tender for (Name of Work) .....

From:

..... (Name in block letters)

.....

..... ( Address in full).

To

The General Manager,  
HFDC, Rewari

Sir

In reference to your Tender No \_\_\_\_\_ Dated \_\_\_\_\_ I do hereby willing to execute works at given rates.

S. No.	Description of Item	Unit	Qty	Rate	Total Amount (Rs.)
1	<b>Manufacturing of Steel Almirah with Material at Furniture Workshop at Masani Barrage, District Rewari as per specifications and drawing</b>	Nos.	01		
	<b>Total Rs.</b>				
	<b>In words</b>				

**Note:**

1. Rates should quoted on the basis of total cost of all the items taken together for approved technical bid.
2. The bidder should assess all the factors including the future increase in the Minimum Wages etc. while quoting the rate, as the quoted rate shall remain the same for the entire contract period.
3. General Manager, HFDC, Rewari is at liberty to increase or decrease the quantity mentioned. Items mentioned may be dropped also keeping in view the requirement of stores/service components at the site/field at the time of placing the work order.
4. The above mentioned quantities are for one room which shall be replicated according to requirement of the site and availability of funds.
5. All statutory obligations under Minimum Wages Act, Contract Labour Act, GST (although GST on forestry works is nil rated) etc. shall be followed by the Contractor. Any report of deviation of violation may lead to termination of contract.
6. All material/service inputs for the above mentioned works shall be provided by the successful tenderer/contractor.

7. The quantity mentioned above may increase or decrease as per requirements of site.

Bank Draft bearing No. .... dated ..... issued by ..... Bank amounting Rs. 40000/- (Rs. Forty thousand only) drawn in favour of Haryana Forest Development Corporation Ltd. payable at Rewari is enclosed.

Date:

Place:

Signature of the tenderer/Applicant

Name:.....

Address:.....

Tel/Mobile No.....

Email:.....



**Undertaking on Letter Head of the Firm/Agency**

Having carefully read all the mentioned terms and conditions of the Tender No. ....  
dated ....., I/we, the undersigned, do hereby certify that all the statement made in the  
attachments are true and correct. I/we hereby undertake that I/we to fully agree the terms and  
conditions of the tender and unconditionally. I/we also undertake to abide by the bid validity of 180  
days. I/we also hereby certify that our firm/agency has not been blacklisted by any government  
agency.

Dated...

Place:

Signature of the bidder

Name .....

H F I D C

**Annexure-I (AFFIDAVIT)**

**TO BE ATTESTED BY NOTARY PUBLIC**

1. I, the undersigned, do hereby certify that all the statements made in the required attachments are true and correct.
2. The undersigned also hereby certifies that neither our firm M/s..... have abandoned any work in Government Organizations nor any contract awarded to us for such works have been rescinded, during last five years prior to the date of this bid.
3. I/We accept all the terms and conditions without any condition.

Date:  
Place:

(Signed by an Authorized Officer of the Contractor/Firm/Agency/Society)

**AFFIDAVIT**



## Annexure-II (Standard Agreement Form)

**(TO BE EXECUTED ON A NON JUDICIAL STAMP PAPER OF RS.100/-)**

AGREEMENT made this \_\_\_\_\_ day of \_\_\_\_\_ 20\_\_\_\_ Between Shri/ M/s. \_\_\_\_\_ of \_\_\_\_\_ (hereinafter referred to as the “Contractor”, which term shall unless the context indicates otherwise, include, besides the said contractor his heirs, executors, administrators, legal representatives and assigns) of the one part and the General Manager, Haryana Forest Development Corporation Limited, Rewari (hereinafter called the “HFDC”) of the other part.

WHEREAS tenders were invited by the HFDC as per tender No. \_\_\_\_\_ dated \_\_\_\_\_ issued by the General Manager for the works mentioned in E-Tender Document under heading SCOPE OF WORK.

WHEREAS the contractor has in his tender dated \_\_\_\_\_ addressed to the General Manager, HFDC, Rewari, submitted his tender for the works mentioned E-Tender Document under heading SCOPE OF WORK and has undertaken to carry out all works according to the specifications/guidelines contained in the conditions/special conditions hereinafter appearing, at his own cost.

WHEREAS the said tender of the contractor has been accepted by the General Manager, HFDC, Rewari subject to the terms, covenants, conditions, special conditions and provisions hereinafter appearing.

WHEREAS the contractor has deposited Rs 200000/- as security for the due fulfillment by him of the terms, covenants, conditions, special conditions and provisions hereinafter contained.

WHEREAS it is understood by and between the parties that the terms and conditions set out in the tender document and the conditions of contract together with all schedules, drawings, sketches, rules appended here to form part of this agreement.

NOW THESE WITNESS that for carrying out the said agreement into execution the contractor for himself, his heirs, executors, administrators, legal representatives and assigns and the General Manager acting for and on behalf of the Haryana Forest Development Corporation Limited, Rewari and his successors and assigns do here by mutually contract with the other and others of them as follows:-

Signature of contractor or  
Authorized representative of Agency/Firm/Society

General Manager, HFDC, Rewari

Witness